

# Valuetest

Economical benchtop test stand

Quantrol™  
by DILLON

precisely



> Above: shown with drill attachment and Basic Force Gauge



> Right: shown with Compact Force Gauge

- > The most economical test stand available
- > Many bolt-on accessories for limitless versatility
- > Throat and base plate extensions for bulky samples

## Valuetest

The Valuetest benchtop test stand offers outstanding value for its extremely tiny price tag. The 500N/110-lbf workhorse has an impressive 15-inch opening. It handles a wide selection of force gauges without special adapter plates. It is backed by the best warranty in the business; two full years on parts and labor.

Many bolt-on accessories make the Valuetest into an extremely versatile tool.

- > Drill-attachment kit motorizes the stand
- > Horizontal leg kit improves ergonomics while seated
- > Base and throat opening extensions allow testing of bulkier samples



A full range of instrumentation, grips and accessories are available to complete your testing solution.

Quantrol's experienced distributors thoroughly understand testing, and can suggest the best combination of equipment for any testing application. They also offer superb maintenance and repair service.

Valuetest is the best choice for budget-minded testing. Ask your Quantrol distributor about it today!

## Specifications:

- > **Capacity:** 500 N / 110 lbf
- > **Headroom & travel:** 15.0 inch / 381 mm
- > **Standard throat opening:** 2.5 inch / 63 mm
- > **Travel per hand wheel rotation:** 0.091 inch / 2.31 mm
- > **Shipping weight:** 24 lbs

## Accessories:

- > **Drill kit:** Fits most T-handle or L-handle drill styles. Max handle size 1.75 inch W x 2.25 inch D
- > **Throat opening extensions:** 1/4 inch spacers extend opening up to 6.0 inch. 208 N / 46 lb rating at 6.0 inch
- > **Oversize base plate:** 8.0 x 8.0 inch
- > **Horizontal mount kit:** Includes leveling feet
- > **Tension plate:** Adjustable front to rear 1.36 inch

## Dimensions:

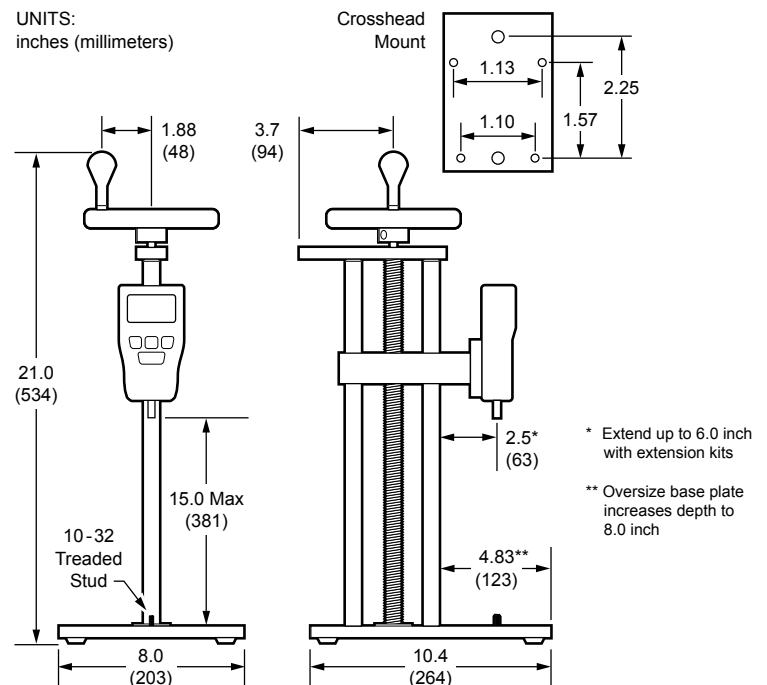

## AUTHORIZED DISTRIBUTORS

**Ask the experts.** Quantrol distributors offer complete service capabilities from application assistance to sales and product support. Their experienced representatives are the most knowledgeable experts that you will find in the force measurement industry. We recommend that you consult these capable specialists for all of your measuring needs.

Please call us or visit  
[www.quantrol.com](http://www.quantrol.com)  
for your nearest  
Dillon distributor.

Quantrol™  
by DILLON

Precision Force  
Measurement  
Testing Systems

A division of Weigh-Tronix Inc.  
Fairmont, Minnesota U.S.A.

Toll-Free: (800) 368-2031  
Phone: (507) 238-8796  
Fax: (507) 238-8258

[www.quantrol.com](http://www.quantrol.com)

